

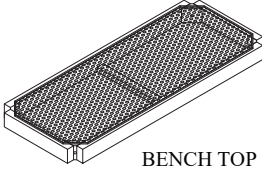

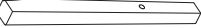

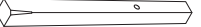



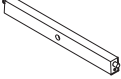

ASSEMBLY INSTRUCTION

ITEM : Oak/Rattan-Bench

NO.	PARTLIST	QTY
1	 BENCH TOP	1PC
2	 LEG	2PCS
3	 LEG	2PCS
4	 BOTTOM SUPPORT RAIL	1PC
5	 SIDE SUPPORT RAIL	2PCS
NO.	HARDWARE	QTY
A	 BOLT M8 X 80	4PCS
B	 SPRING WASHER	4PCS
C	 FLAT WASHER	4PCS
D	 NUT	4PCS
E	 SCREW M3.5 X 40	6PCS
F	 WRENCH	1PC
G	 FELT MA	4PCS

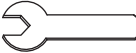
STEP 1

Insert bolt(A) into leg(2)&(3).

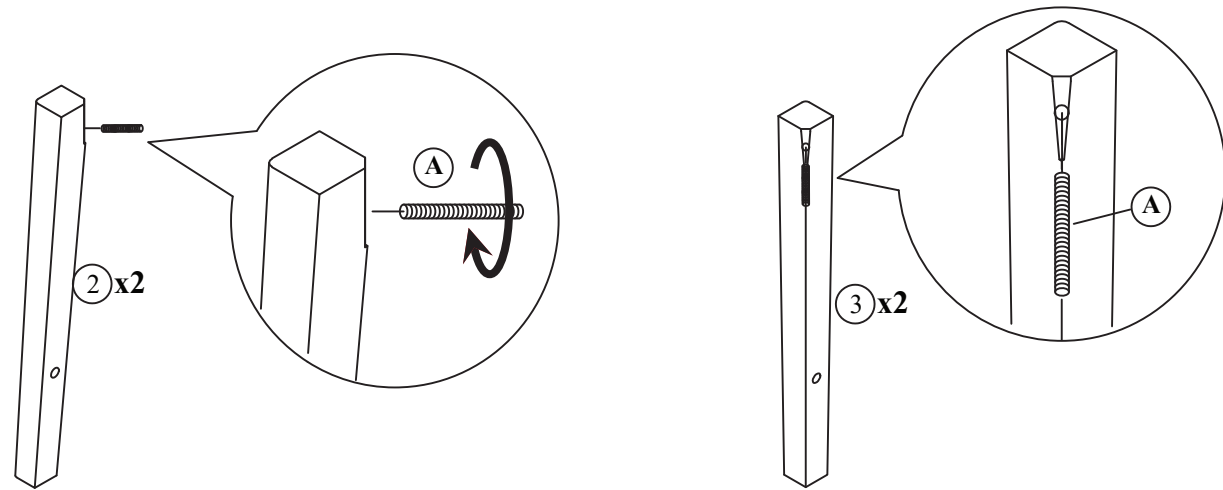

STEP 2

Put seat (1) upside down on the floor, pay attention to protect it. Fix leg (2) & (3) with bench top (1) by flat washer (C), spring washer (B), bolt (A) and Allen key (D).

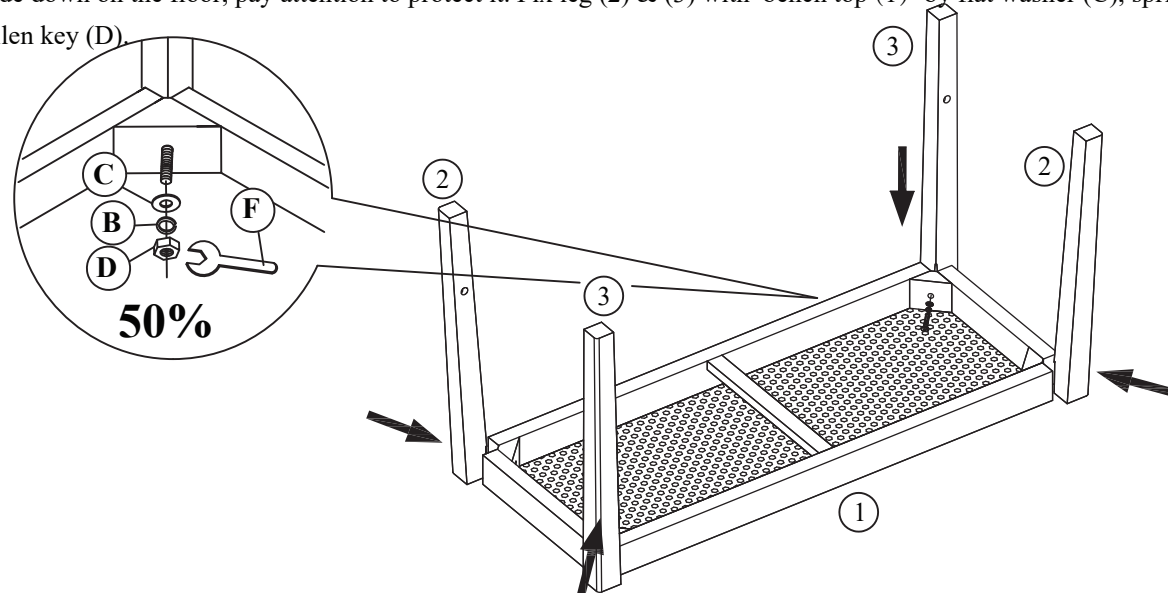

ASSEMBLY INSTRUCTION

STEP 3

Fix bottom support rail (4) with side support rail (5) by screw (E).

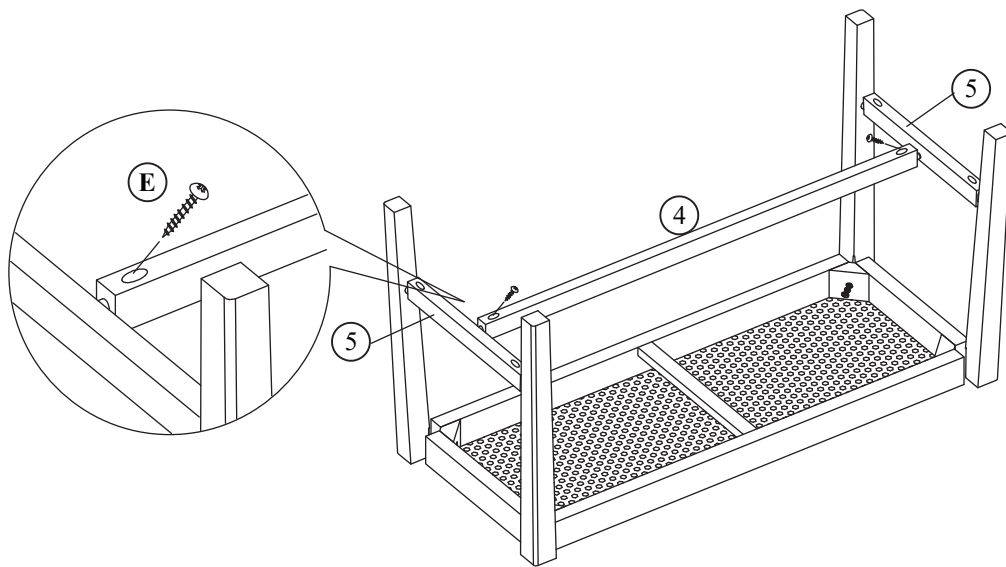

STEP 4

Add felt pad (F) on bottom of leg. Fix side support rail with leg by screw (E).

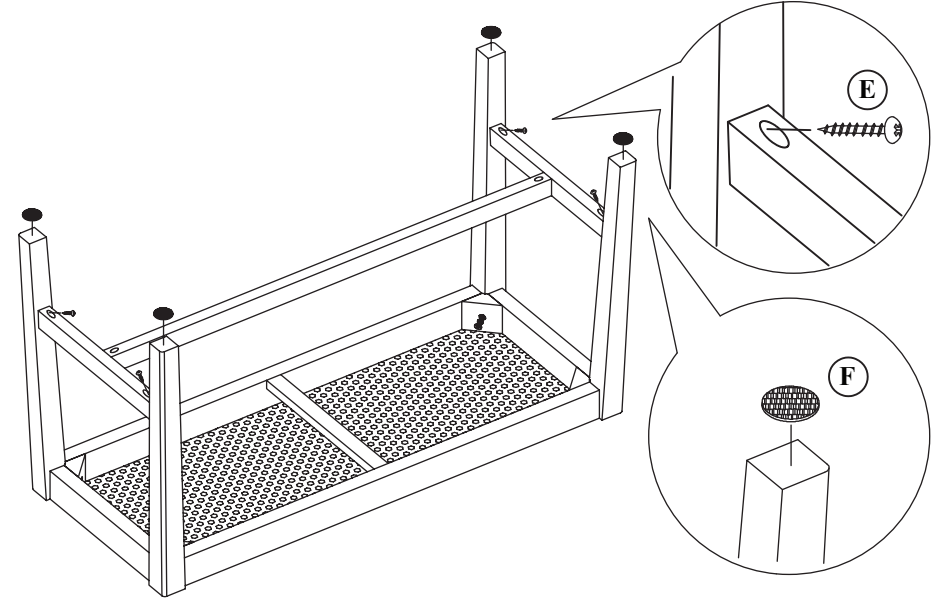

STEP 5

Tight bolt 100%.

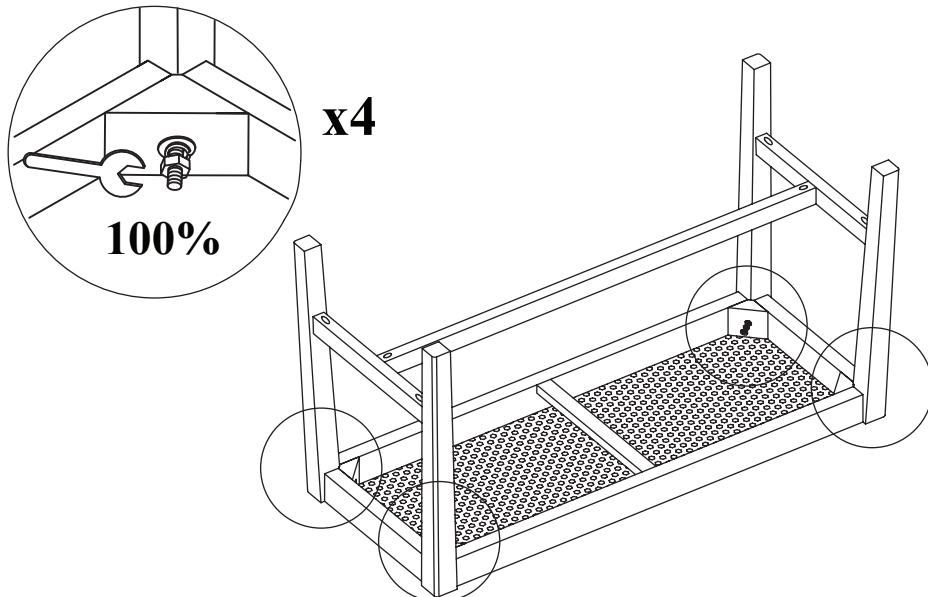

STEP 6

Rotate bench.



ASSEMBLY COMPLETED

NOTE : AFTER A FEW DAYS OF ASSEMBLY. IT WILL HAVE ACCLIMATIZED TO THE ENVIRONMENT. PLEASE TIGHTEN ALL HARDWARE.CHECK TIGHTNESS OF ALL SCREWS EVERY 6 - 8 WEEKS.